COMPUTER SECURITY

- Cryptography: THE security mechanism ([2](#))
 - Basics ([3](#))
 - Classification of cryptographic systems ([12](#))
 - On the secret ([13](#))
 - On the method ([15](#))
 - On the purpose ([17](#))
 - Cryptographic Keys ([21](#))
 - Key types of cryptographic keys ([21](#))
 - Key Management ([22](#))
 - Randomness ([25](#))
 - Cryptographic libraries ([26](#))
 - Cryptographic algorithms ([27](#))
 - Cryptographic transformations ([28](#))
 - Some numbers... ([31](#))
 - Pointers... ([32](#))

Cryptography: THE security mechanism ¹

"Security!" --> "1676c0cf7e901d443bd9cad6c5253fee"

(AES cipher, ECB mode, PKCS#7 padding, 128-b key: "I am JohnDoe 007";
French quotes are just delimiters.)



Digitally signed by Lisa Jones
DN: cn=Lisa Jones, o=Kahili Coffee Company,
ou=Sales
Reason: I have reviewed this document
Date: 2004.07.14 13:17:03 -07'00'

¹ However, keep in mind: «*Cryptography is rarely ever the solution to a security problem.*» (D. Gollmann, Computer Security, p. 203)

Basics

History

- Originally:
 - science (and art) of secret writing
 - aimed at hinder the knowledge of sensitive information
- Currently:
 - science (and art?) of providing mechanisms to ensure security properties (confidentiality, integrity...)
 - aims to control the access to information

...Basics...

Practical uses

- Traditional:
 - control access to information by **concealing** it, i.e. making it unintelligible
- Modern:
 - the traditional, plus
 - control access to information by **identifying** it with a *fingerprint* (or *hash*¹)
 - **support** all above uses
 - produce (almost) random numbers
 - derive secret numbers (keys)²

Relevant types of professionals:

- *cryptographers* - try to master and enhance that access control
- *cryptanalysts* - try to break the enabled access control

1 PT: *síntese, sumário*

2 pieces of data necessary for using cryptographic security mechanisms

...Basics...

Notation

<i>Symbol</i>	<i>Name of symbol</i>	<i>Meaning of symbol</i>
<i>P</i>	plaintext ¹	original, uncovered information
<i>E</i>	enciphering algorithm	method to conceal the info
<i>K_e</i>	enciphering key	parameter of the concealment methods
<i>C</i>	ciphertext	hidden information
<i>D</i>	deciphering algorithm	method to recover the original info
<i>K_d</i>	deciphering key	parameter of the recovering methods
<i>H, h</i>	hash algorithm, hash value	method to transform (hash) the info, transformed info
<i>F</i>	fingerprint, hash value	transformed info

1 PT: texto inteligível

...Basics: Notation...

Operation	Symbolic representation	If...	Cryptography type
cipherring	$C = E_{K_e}(P)$	$K_e = K_d$	symmetric
	$C = E(P, K_e)$ $C = K_e(P)$		
deciphering	$P = D_{K_d}(C)$	$K_e = K^+$ $K_d = K^-$	public-key (asymmetric)
	$P = D(C, K_d)$		
	$P = K_d(C)$		
(cryptographic) hashing ¹	$h = H(P)$ $F = H(P)$ $F = h(P)$		
reversing	$D_{K_d}(E_{K_e}(P)) = P$		

Advance notice for Digital Signature:

$$[Doc]_E \iff K_E^-(Doc) \iff K_E^-(H(Doc))$$

¹ Note: *cryptographic* hashing is different from *database* hashing.

Traditional use of Cryptography

- confidentiality protection:
 - conceal information, by making it unintelligible
 - elsewhere or later, retrieve original information

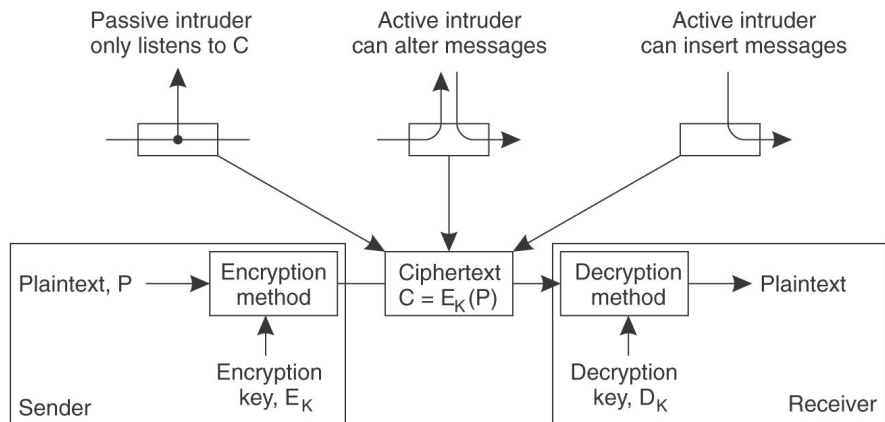

Fig. Original Cryptography: basic model of concealment and recovery of info with examples of attacks (*in several of Tanenbaum's books*).

...Basics...

Added, newer, usage of Cryptography

- integrity protection:
 - information is *fingerprinted*,¹ by calculating its *hash (or digest)*
 - elsewhere or later, the hash will be used to detect the adulteration of the original information

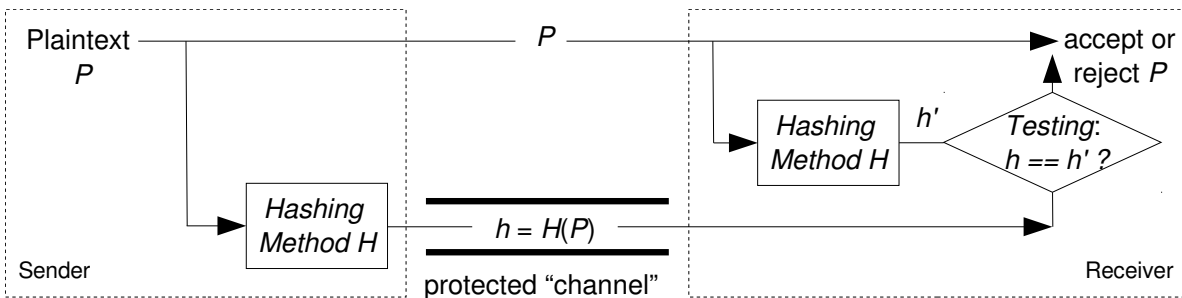

Fig. Newer use of Cryptography: basic model for the validation of info (e.g. integrity protection).
Note the need for a protected channel!

¹ small array of bytes that represents the original information

Breaking cryptographic systems

- Professionals: cryptanalysts, random crackers
- Methods: mathematics, statistics, intuition¹
- Goals: depend on type of usage

Attacks in traditional use

- Goal: grasp the deciphering key! Sometimes, at least, grasp plaintexts.
- Approaches (in descending order of difficulty):
 - normal
 - only ciphertexts are available
 - known original text (“passively” obtained)
 - both some original texts and their enciphered counterparts are available
 - planned original text (“actively” prepared)
 - specific original texts are made to be enciphered

¹ For an example, see Bishop: "Introduction", Chap.8; "Art & Science", chap.9.

...Basics: Breaking cryptographic systems...

Attacks in added recent usage

- Goal: break integrity protection
- Approaches¹ (in descending order of difficulty):
 - find collisions²
 - produce chosen document pairs (*birthday attack*³)
 - produce another document for a specific original

1 The special case of "digital signatures" will be seen elsewhere.

2 meaning: different documents with same fingerprint

3 https://en.wikipedia.org/wiki/Birthday_attack

Ideal cryptographic system's requirements

- hard to break
 - in a reasonable future horizon
 - formal proof would be nice...
- easy to use
 - otherwise will be rejected or bypassed by users
- if broken, easily replaceable
 - this should be a must, as systems **will** be broken!
 - depends on what was broken (type of secret)

Classification of cryptographic systems

<i>Perspective</i>	<i>Variant</i>	<i>Sub-variant</i>	<i>Examples</i>
on the secret	secret algorithm		RC4, Crypto1 (¹)
	secret key(s)	single key, shared-key, symmetric	AES
		two-key, public key, asymmetric	RSA
on the method	stream ²		RC4, One-time pad
	block	(pure)	AES, RSA ³ in ECB ; SHA-2
		<i>mixed</i>	AES in CBC
on the purpose	bidirectional, reversible, two-way	symmetric (for confidentiality ⁴)	AES
		asymmetric (for authentication ⁵)	RSA
	unidirectional, irreversible, one-way	(for integrity)	SHA-2, SHA-3
	mixed	(for confidentiality & integrity)	AES-CBC-HMAC-SHA1

1 Originally, both were secret; now, they are **not**!

2 PT: *continuo, sequencial*

3 Many authors do not ever classify asymmetric systems (e.g. RSA) as "block"... (more on this later)

4 usually, with temporary keys

5 main usage, with personal and durable (long-lasting) keys

...Classification of cryptographic systems

On the secret

<i>Perspective</i>	<i>Variant</i>	<i>Comments</i>	<i>Exs</i>
on the secret ...	secret algorithm	<ul style="list-style-type: none">• used in closed applications: military, commercial• not recommended by academics¹	RC4 ² , Crypto1
	secret key(s) ...	<ul style="list-style-type: none">• used everywhere: military, commercial, personal applications• recommended by academics³	AES ⁴ , RSA ⁵

1 because, sooner or later, the secret will be discovered and a replacement is always difficult

2 Rivest Cipher 4

3 and by common sense as well, if history is something to go by

4 Advanced Encryption Standard

5 Rivest-Shamir-Adleman

...Classification of cryptographic systems: on the secret

Perspective	Variant	Sub-variant¹	Comments	Exs
... on the secret	... secret key(s)	single key, shared-key, symmetric: $K_e = K_d = K$	<ul style="list-style-type: none"> • heuristic constructions <ul style="list-style-type: none"> • very efficient computation: <ul style="list-style-type: none"> • very suitable for large amounts of data • difficult combination and sharing of key: <ul style="list-style-type: none"> • preferred for closed environments 	AES
		two-key, public key, asymmetric: $K_e = K^+$ \neq $K_d = K^-$	<ul style="list-style-type: none"> • math-based constructions <ul style="list-style-type: none"> • very heavy computation: <ul style="list-style-type: none"> • not suitable for large amounts of data • easy combination and exchange of keys: <ul style="list-style-type: none"> • ideal for open environments 	RSA

1 often, the two sub-variants are used in conjunction (more on this later...)

On the method

“Long” texts¹

- cryptographic operations² have to be done on (equal sized) pieces (blocks)³
 - typical size: 8 B (64 b) and 16 B (128 b)⁴
- enciphering (and deciphering)
 - *modes of operation*,⁵ are ways to use keys in the processing of each piece
- hashing
 - does not use keys (in general)
- final piece might need to be “padded”⁶
 - as, in general, data size is not a multiple of the piece size

1 In practice, almost any text is “long”...

2 ciphering, deciphering, hashing

3 $P = P_1 P_2 \dots$

4 could be 1 b, 1 B, ...

5 to be discussed later

6 to be discussed later

...Classification of cryptographic systems: on the method

Perspective	Variant	Sub-variant	Comments¹	Exs
on the method	stream		<ul style="list-style-type: none"> each piece is (de)ciphered with a different key, $K = K_1 K_2 \dots$ e.g. $C = K(P) = K_1(P_1) K_2(P_2) \dots$ 	RC4, One-time pad
	block	(pure)	<ul style="list-style-type: none"> each piece is (de)ciphered with the same key, K e.g. $C = K(P) = K(P_1) K(P_2) \dots$ fingerprinting does not use keys in general, $F = H(P) = H(P_1) H(P_2) \dots$ 	AES, RSA ² (both) in ECB ³ mode ; SHA-2, SHA-3 ⁴
		<i>mixed</i>	<ul style="list-style-type: none"> each piece is (de)ciphered with a "virtual" different key, combination of the same key with additional (and different) information per block 	AES in CBC ⁵ mode

1 will apply to (de)ciphering, as hashing does not use keys

2 Many authors do not consider RSA to be a block cipher, as it is not efficient enough to be used consecutively (block after block) in long documents. E.g., see section 3.5 of Peter Gutmann, [Lessons Learned in Implementing and Deploying Crypto Software](#).

3 Electronic Code Book

4 SHA: Secure Hash Algorithms

5 Cipher Block Chaining

...Classification of cryptographic systems

On the purpose

<i>Perspective</i>	<i>Variant</i>	<i>Sub-variant</i>	<i>Comments</i>	<i>Exs</i>
on the purpose	bidirectional, reversible, two-way	symmetric	<ul style="list-style-type: none">usage: mostly, confidentiality¹(see picture C below)	AES
		asymmetric	<ul style="list-style-type: none">usage: mostly, authentication² ; also confidentiality³(see picture A1 below)	RSA
	unidirectional, irreversible, one-way		<ul style="list-style-type: none">usage: authentication, integrity(see pictures A2, I below)	SHA-2, SHA-3
	mixed		<ul style="list-style-type: none">usage: mostly, both confidentiality & integrity(see picture CI below)	AES-CBC-HMAC-SHA1

1 with temporary keys

2 with personal and durable (long-lasting) keys

3 of small amounts of data, e.g. symmetric keys

...Classification of cryptographic systems: on the purpose...

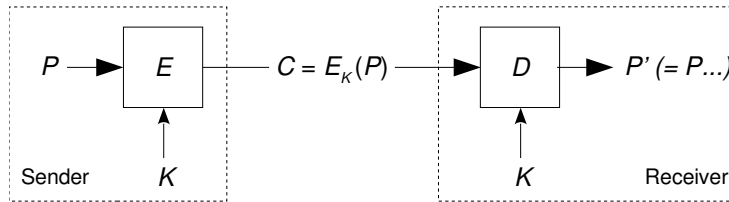

Fig C. Confidentiality with symmetric cryptography.

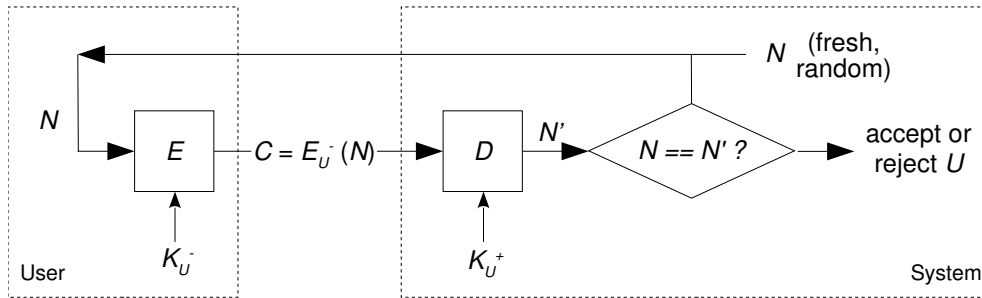

Fig A1. Authentication with asymmetric cryptography.

...Classification of cryptographic systems: on the purpose...

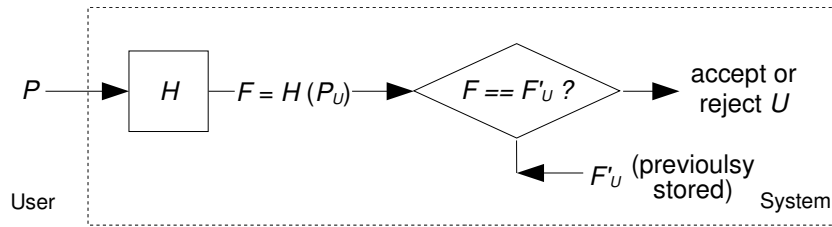

Fig A2. Authentication with cryptographic hashing.

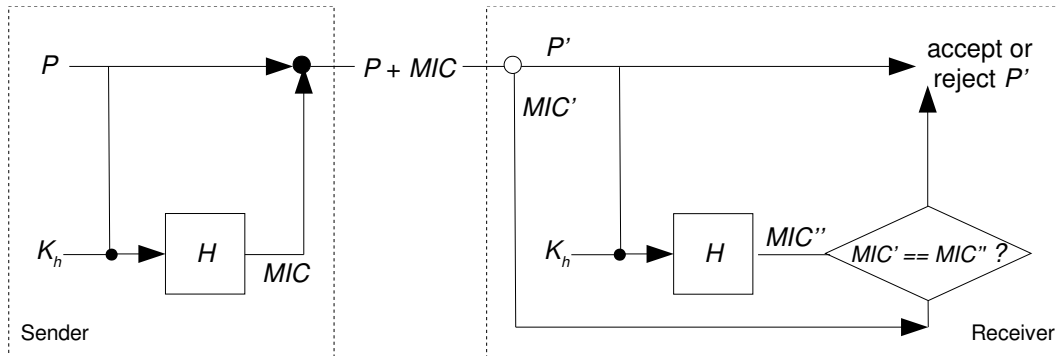

Fig I. Integrity with cryptographic hashing.

...Classification of cryptographic systems: on the purpose

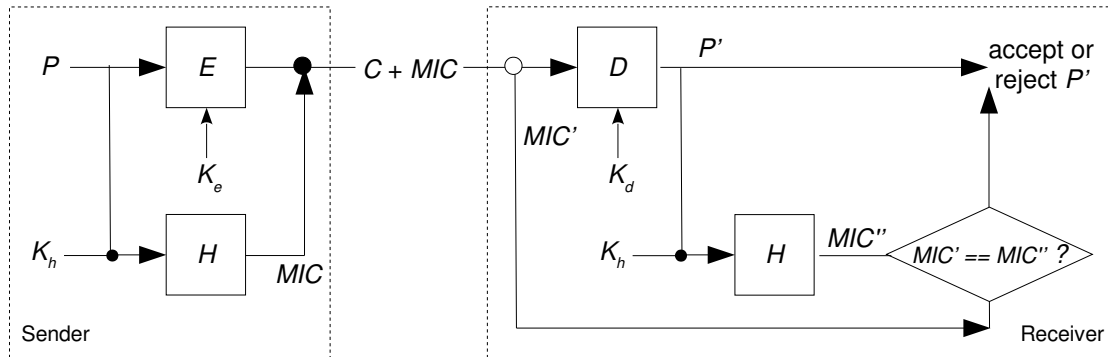

Fig CI. Confidentiality & Integrity (Authenticated Encipherment).

Cryptographic Keys

Definition

- cryptographic key – piece of data needed for cryptographic operations
 - usually: number or string hard to memorize
 - some times: fit to a mathematical procedure (algorithm)¹
 - most of the times: secret

Key types of cryptographic keys

<i>Designation</i>	<i>"Owner" entity</i>	<i>Main application</i>	<i>Cryptographic type</i>	<i>Longevity</i>	<i>Efficiency</i>
personal	human	authentication	public-key	extended	low
session	communication channel	confidentiality	shared-key	short ²	high ³

1 so, user cannot "choose" it: a "cryptographic key generator" is needed

2 to be use-resistant (prevent brute-force search and repetition attacks)

3 so, can accommodate heavy traffic

Key Management

- generation
 - problem solved: just take care with choosing of seed values¹
- storage
 - many "solutions", but still a problem swept under the rug!
- distribution
 - big problem:
 - physically separated entities must exchange/agree on cryptographic keys
 - solutions:
 - several, depending on type of cryptography (symmetric or asymmetric)
 - specific of asymmetric:
 - *public key* is distributed mostly by digital certificates

¹ here, randomness is essential

...Key Management: Digital Certificate...

Digital certificate

- document that maps an entity to a cryptographic public key
 - the mapping is guaranteed by T ,¹ by digital signing the document²

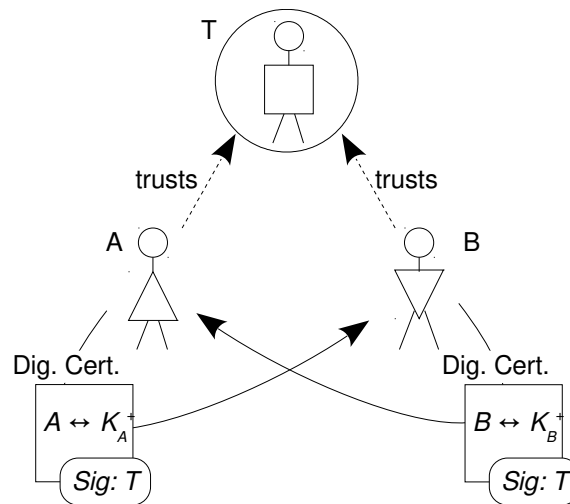

Fig. Representation of users, trusted certificate emitter and digital certificate's essential content.

- 1 T is entity trusted by A and B : 1- they believe T operates in an honest way; 2- they have previously exchanged cryptographic info with T . Usually, but not necessarily, T is connoted with a *Certification Authority* (CA).
- 2 so, assuring the legitimacy of the certificate's content; technique will be discussed later

...Key Management: Digital Certificate

Typical content

I hereby certify that the public key 19836A8B03030CF83737E3837837FC3s87092827262643FFA82710382828282A belongs to Robert John Smith 12345 University Avenue Berkeley, CA 94702 Birthday: July 4, 1958 Email: bob@superdupernet.com
SHA-1 hash of the above certificate signed with the CA's private key

Fig. *Really* relevant content type of a digital certificate (*in* several of Tanenbaum's books).

- identity of key's owner
- his/her public key
- identity of emitter¹
- digital signature of emitter
- expiration date of certificate
- serial number
- specific purpose
- etc.

1 e.g. typically, a Certificate Authority

Randomness

- essential in Cryptography!
 - one time pad, IV (initialization values), stream cipher seeds
 - hashes
 - *nonces*, key generation (e.g. asymmetric keys)...
- generation
 - excellent: physical source
 - inherent: radioactive decay, Brownian movement, ...
 - depending on initial conditions: (non-biased) roulette, dice, ...
 - reasonable: algorithmic-based with physical seed
 - cryptographically secure pseudorandom number generators
 - use physical (hopefully random) sources (e.g. mouse movements)
 - Linux's `getrandom()` (`/dev/random`, `/dev/urandom`)
 - bad: algorithmic-based
 - pseudorandom number generators
 - POSIX's `random()`

Cryptographic libraries

- essential in cryptographic programming
 - encryption, hashing, signing... different algorithms... all ready to be used
 - coupled with a "*cryptographically secure pseudorandom number generator*"
 - why not write your own library?
 - Highly dangerous! It is not just implementing algorithms, it is how they are used, how "random" numbers are generated and chosen, etc.¹
- examples
 - OpenSSL: the reference!²
 - components: application & C library
 - EVP (envelope) "high level" API (lab classes)
 - WebCrypto: JavaScript (by W3C)
 - Bouncy Castle: Java and C# (by Australia's Legion...)
 - Libgcrypt: C (OpenPGP library) (by GnuPG community)
 - PyCryptodome: Python

1 see, for instance, <https://security.stackexchange.com/questions/18197/why-shouldnt-we-roll-our-own>

2 in spite of same infamous bugs, such as *The Heartbleed Bug* (heartbleed.com)

Cryptographic algorithms

- [RC4](#): stream key generation (1987, survives with medication)
- [DES](#)¹: reversible system, secret key (1975, defunct)
- [AES](#): reversible system, secret key (1998, still healthy)
- [RSA](#)²: reversible system, public key (1977, still healthy)
- [MD5](#)³: irreversible system (1992, defunct)
- [SHA-1](#)⁴: irreversible system (1995, defunct)
- [SHA-2](#): irreversible system (2001, still healthy)
- [SHA-3](#)⁵: irreversible system (2015, yet in phase of wide adoption)

1 Data Encryption Standard, a landmark of cryptography

2 another landmark of (public-key) cryptography

3 yet another landmark of cryptography

4 about SHA-1 end of life, see sha-mbles.github.io

5 based on new paradigm - sponge construction (keccak.team/sponge_duplex.html)

Cryptographic transformations

- diverse, generally follow some major "patterns" for each type of cryptography
- in general, Shannon's recommended properties¹ are followed:
 - *diffusion* – each plaintext unit (e.g. char) affects many transformed units
 - *confusion* – transformed output depends complexly on key (if it exists)

Common patterns² - symmetric cryptography

- Transposition – exchange (swapping) of positions of elements – *P-box*
- Substitution – exchange of elements (e.g. Caesar's cipher) – *S-box*
- Combination - transposition and substitution cascade – *product cipher* [Fig.C]
- Feistel construct (e.g. 3DES) [Fig.F]
- ...

1 Those were thought to symmetric cryptography, the only that existed at the time (1949); however, they are applied, at least partially, to other, contemporary cryptographic systems.

2 or transformations

...Cryptographic transformations: common patterns...

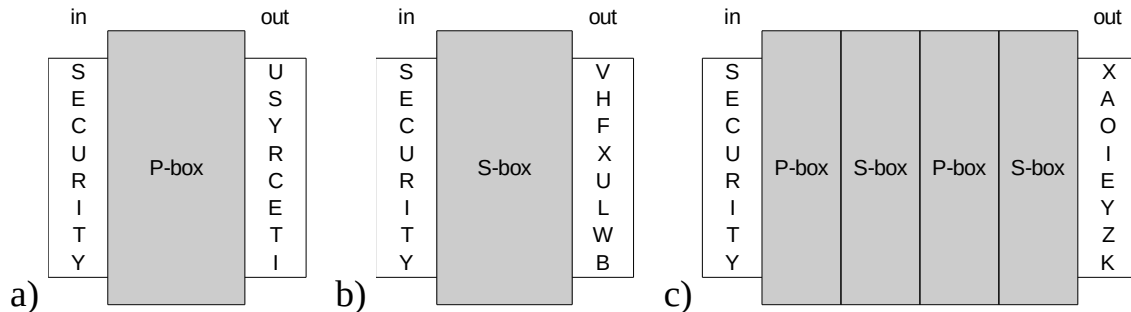

Fig C. Symmetric transformations: a) permutation box; b) substitution box; c) “complete”, product cipher. Exercise: find out the algorithms for P- and S- boxes and validate them with c).

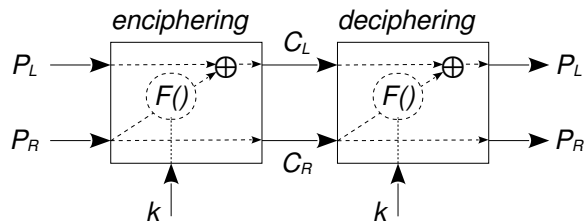
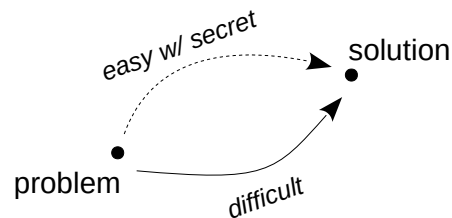

Fig F. Feistel symmetric construct "in action". F is Feistel (or round) function.

...Cryptographic transformations: common patterns...

Common patterns - asymmetric constructs

- based on apparent intractability of computational problems:
 - easy to compute with knowledge of some data; otherwise, most difficult (intractable) to compute¹
 - common computational problems:
 - integer factorization (e.g. RSA)
 - discrete logarithm problem (e.g. DSA)
 - ...



Common patterns - "hash" cryptography

- most common are *iterated hash functions*
 - Merkle-Damgård construct (e.g. SHA-2)
 - sponge construct (e.g. SHA-3)
 - ...

¹ Informally, an easy or tractable problem can be solved in less than n^k (polynomial) time units, k being an integer and n the size of the problem (e.g. number of items to sort); a hard or intractable problem will need k^n (exponential) time units to be solved.

Some numbers...

- $2^8 = 256$ number of values represented by a byte
- $2^{32} = 4\,294\,967\,296$ maximum number of IPv4 addresses
 $\simeq 0,5 * \text{number of people on Earth in 2023}$
- $2^{56} = 72\,057\,594\,037\,927\,936$ number of different keys for DES algorithm
- $2^{64} = 18\,446\,744\,073\,709\,551\,616$
1+ number of grains of wheat in chess board (from 1, doubled in each square)
- $2^{76} \simeq 10^{23}$ mass of the Moon in kg
- $2^{79} \simeq 10^{24}$ Avogadro's constant
- $2^{82} \simeq 10^{25}$ mass of the Earth in kg
- $2^{101} \simeq 10^{30}$ mass of the Sun in kg
- $2^{128} = 340\,282\,366\,920\,938\,463\,463\,374\,607\,431\,768\,211\,456$
 $\simeq 10^{38}$ maximum number of IPv6 addresses
- $2^{256} \simeq 10^{77}$ number of values of SHA-256 hash
- $2^{280} \simeq 10^{84}$ number of fundamental particles in the observable universe

Pointers...

- The “**Public-key cryptography paper**”, 1976 – W. Diffie , M. E. Hellman
 - www-ee.stanford.edu/~hellman/publications/24.pdf
- The “**RSA paper**”, 1978 - R. L. Rivest, A. Shamir, and L. Adleman
 - dx.doi.org/10.1145/359340.359342
- The “**ElGamal Signature Scheme**”, 1985 - Taher Elgamal
 - ieeexplore.ieee.org/stamp/stamp.jsp?arnumber=01057074
- The “**DES Cryptanalysis paper**”, 1977 – W. Diffie , M. E. Hellman
 - www-ee.stanford.edu/~hellman/publications/27.pdf
- The “**Rijndael, AES Proposal**”, 1999 - Joan Daemen, Vincent Rijmen
 - citeseerx.ist.psu.edu/viewdoc/summary?doi=10.1.1.36.640
- The “**MD5 Message Digest Algorithm**”, 1992, R. Rivest
 - tools.ietf.org/html/rfc1321
- The “**The Keccak SHA-3 submission**”, 2011, G. Bertoni et al.
 - keccak.team/files/Keccak-submission-3.pdf
- The “**Crypto Mini-FAQ**”, Internet FAQ Archives, -2014, Roger Schlafly
 - www.faqs.org/faqs/crypto/faq/